

# MOUNTING INSTRUCTION

## GROUND MOUNTED SYSTEMS duplex field



## CONTENTS

1. GENERAL AND SAFETY INSTRUCTIONS .....	3
2. OVERVIEW OF THE SYSTEM COMPONENTS .....	5
3. ASSEMBLY .....	6
3.1 Pre-Assembly of the stand-posts .....	6
3.2 Calibration of the solar system / Calibration of the stand posts.....	6
3.3 Attaching the triangles.....	7
3.4 Module assembly .....	8
3.5 Installation of the connector sheets.....	9
3.6 Ballasting.....	10
3.7 Final check of the assembly .....	10

## 1. GENERAL AND SAFETY INSTRUCTIONS

### Notes on intended use

These installation instructions describe the intended installation of the dupleX field mounting system on flat or low-sloped roofs. The installation is to be carried out exclusively by specialist companies. These installation instructions are specifically intended for the installer of the substructure.

### In addition to these assembly instructions, you will need

- a layout plan (included in the scope of delivery)
- a ballasting plan (included in the scope of delivery)

### Safety instructions

The relevant safety regulations apply that must be observed when installing solar systems on flat and low-sloped roofs; in particular, the valid safety and accident regulations in accordance with § 15 SGB VII should be observed.

### Applicable Standards and regulations

The relevant standards and regulations that must be observed during the installation of solar systems apply, in particular the latest version of the applicable regulations:

VDEW Guidelines

Technical connection conditions of the energy supply companies

BGV A1 Accident prevention regulations

BGV A3 Electrical installations and equipment

BGV C22 Construction work

BGV D36 Ladders and steps

DIN 1055 Part 4 and Part 5 Wind and snow loads

For the installation of the dupleX field mounting system and the associated warranty claims and guarantees, these installation instructions must be observed.

## Important mounting instructions

Observe the following recommended torques when tightening the hexagon nut/bolts:

- M6 = 8 Nm
- M8 = 16 Nm

Modules mounted in a line next to each other are called rows, i.e., they run in north-south direction. The brackets run parallel in the east-west direction.

## Provision of the plant base

Before starting installation, make sure that the substrate of the plant is in a load-bearing condition. All possible interfering factors for a complication-free assembly must be eliminated. Note that the difference in level from post to post must not exceed 180mm.

## Ballasting

Ballasting is carried out before the modules are installed. Take the prescribed amount of ballast from the ballasting plan.

## Interruption of the assembly before completion

If for any reason you need to interrupt assembly before completion, you must check all boxes to ensure that both modules are assembled and ballasted to withstand intermediate wind attacks.

## Delivery

The system parts and the assembly material are delivered in closed pallets. The delivery bills are located on the outside of the pallets. When unpacking, check that the delivered goods are intact and complete. If the delivery is incomplete or parts are damaged, then inform the supplier or Profinal Handels GmbH.

## Tools

To mount the substructure, all you need is a cordless screwdriver (alternative: nut with ratchet or 10 mm open-end wrench) with a 10 mm, 13 mm and a 17 mm nut. For module assembly you need an Allen key.

## 2. OVERVIEW OF THE SYSTEM COMPONENTS

	
<p><b>Triangle</b></p>	<p><b>Post</b></p>
	
<p><b>Baseplate</b></p>	<p><b>Connector Sheets</b></p>
	
<p><b>End clamp</b></p>	<p><b>Middle clamp</b></p>

## 3. ASSEMBLY

### 3.1 Pre-Assembly of the stand-posts

**Oblong holes on the top!**

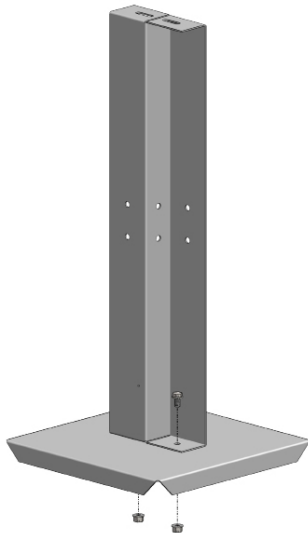

In the first step, after unpacking the components, screw the uprights to the base plates. To do this, use M8x20 screws and the corresponding nuts.

Make sure that the slotted holes are at the top.

### 3.2 Calibration of the solar system / Calibration of the stand posts

Measure the PV system according to the enclosed installation plan. First mark the subsequent position of the system on the site and pay particular attention to the restricted areas or maintenance aisles specified in the installation plan. A rope scaffold is recommended.

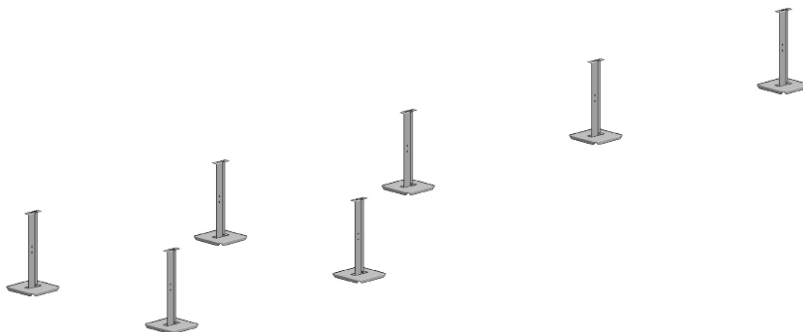

Now place the stand posts at the specified positions. Start with the posts on the northern side and from there from east to west.

### 3.3 Attaching the triangles

To begin with, place the folded consoles (delivery condition) from east to west on the stand posts and screw them together with M6x16 bolt and M6 nut.

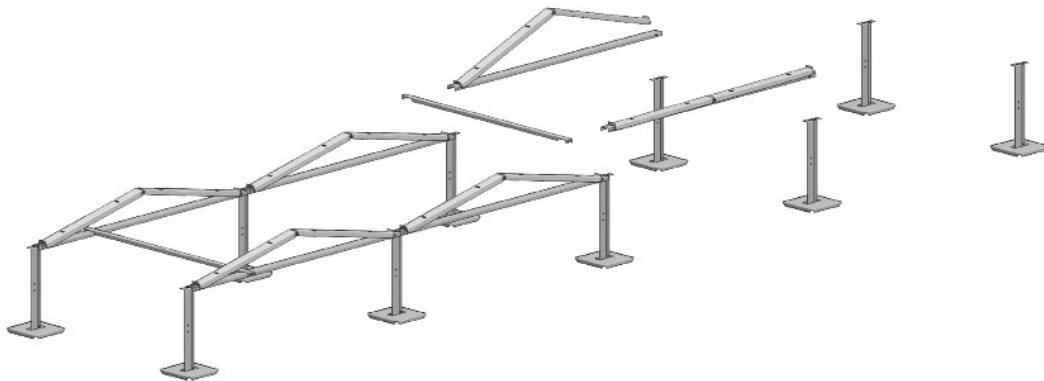

Now the legs of the bracket are erected and placed at the front on the screws already preassembled in the tension rail. Then align the console and tighten all screw connections.

Proceed in the same way with the following brackets and first completely assemble **two north-south rows** from east to west. Now the module is assembled for this section. Proceed in the same way for the further assembly.

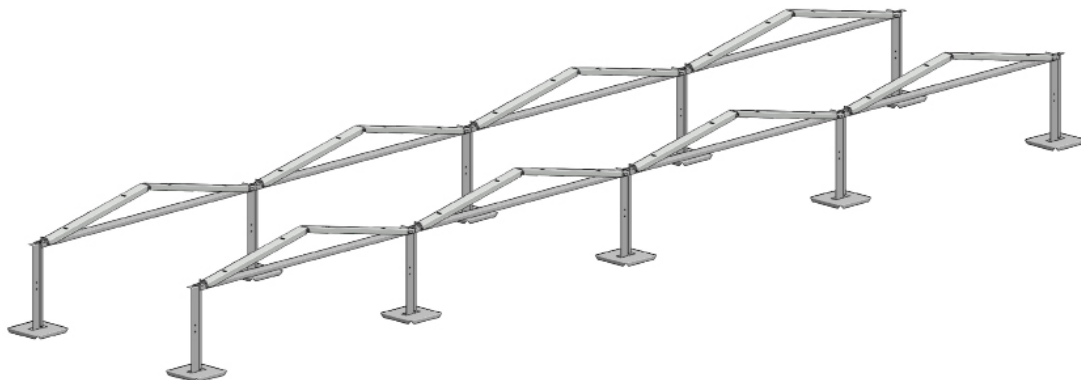

### 3.4 Module assembly

Insert the end clamps into the slots provided in the consoles at the northern start of the row. Then place the first modules with the frame on the backslash and fold them onto the console. Now slide the module to the correct position on the console.

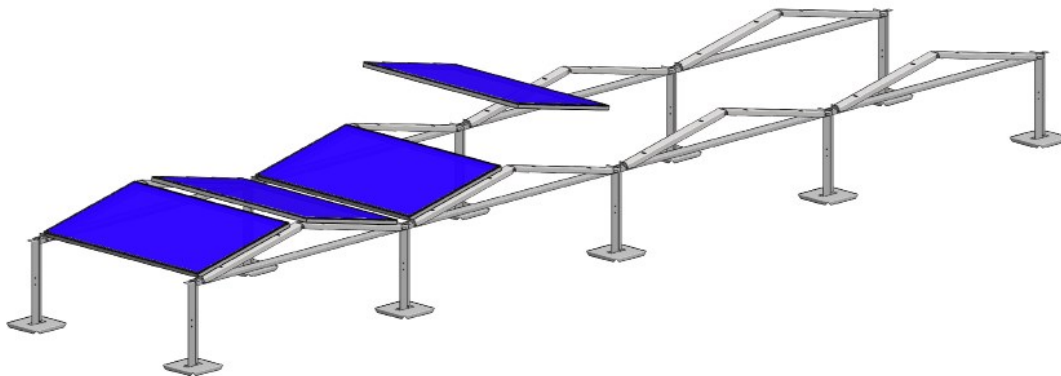

The edge of the module frame should be 10mm from the center of the stand on both sides. Now tighten the end clamps to **6 Nm without impact**. Next, insert the center clamps into the slots provided in the brackets.

Now lay out the posts and brackets for the next row at module distance. Now place the next modules on the consoles and slide them into position. The distance between the modules is determined by the clamps. Therefore, make sure that the first modules of each row are exactly in position.

Proceed in the same way with all further modules of the row.

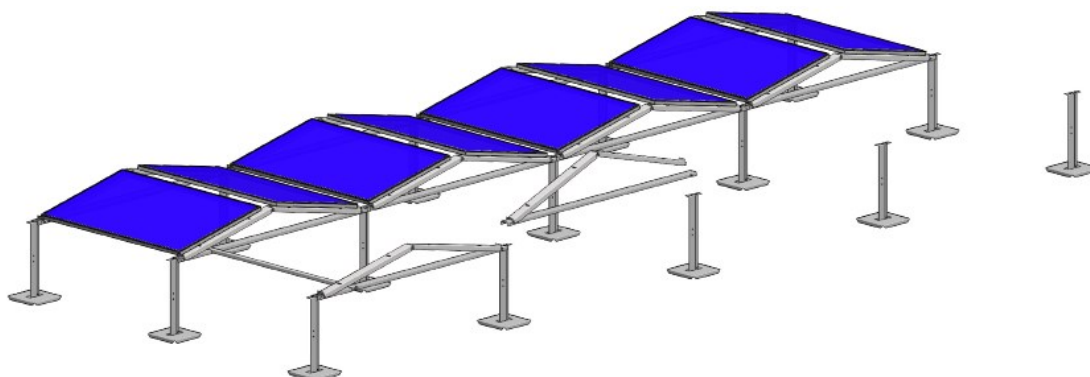



**Please note:** Never, for example, install all the uprights and brackets first and only then the modules. A deviation from this assembly sequence can lead to considerable additional work when laying the modules.

### 3.5 Installation of the connector sheets

After completing the module assembly, install the stiffening plates. Up to ten such composite plates are required per module field (maximum 720 modules) (five east-west and five north-south). The exact number and position depends on the individual design of the single module field.

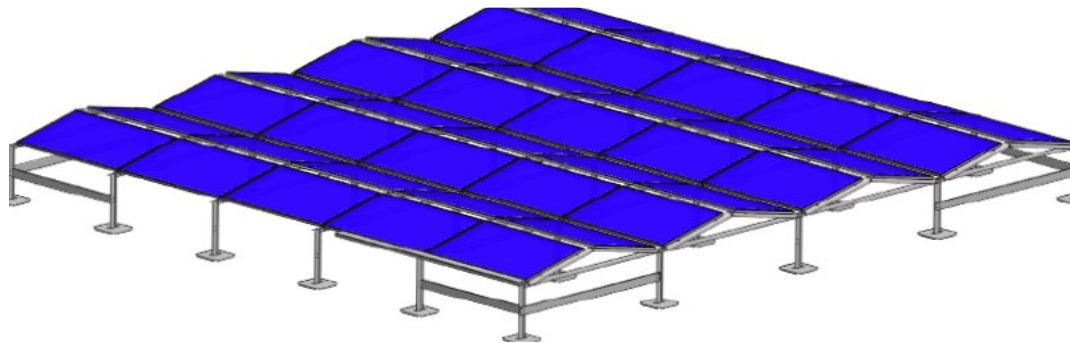

**As a general rule,** install at least two stiffening plates in each direction and on each side. Stiffeners must also be installed at interruptions or at inside and outside corners. Screw the plates to the uprights using an M8x16 screw and nut M8 to the uprights of the relevant positions. Use the holes provided for this purpose in the stand posts

### 3.6 Ballasting

Ballasting is carried out before the modules are installed. Take the prescribed amount of ballast from the ballasting plan.

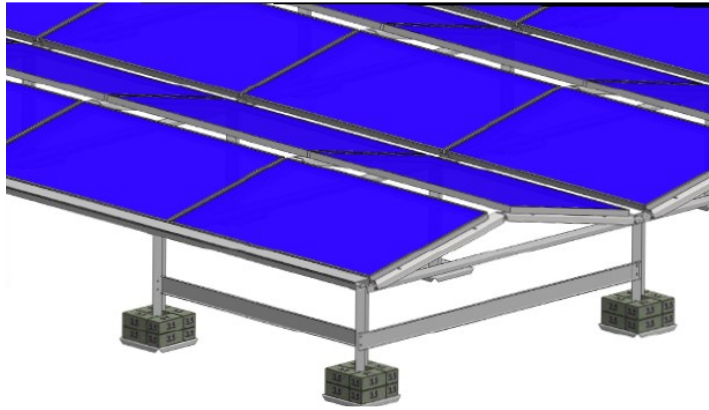

Distribute the ballast on the base plates. The ballast can be applied both with concrete blocks or bags filled with gravel or pebbles. In particular, prevent accidental tipping of concrete blocks, etc.

**Attention:** The specifications in the ballasting plan must be observed.

### 3.7 Final check of the assembly

Finally, check whether all individual parts have been installed and all screw connections have been tightened. You must also check whether the ballast has been completely attached in the correct place.

Thank you for choosing a **PROFINAL** mounting system.

**PROFINAL** systems are quick and easy to install and we hope that these instructions have helped you.

If you have any suggestions, questions or ideas for improvement, please do not hesitate to contact us.

All contact details can be found at:  
[www.profinal-aluminium.de](http://www.profinal-aluminium.de)

We will be happy to advise you!

**PROFINAL** Handelsgesellschaft mbH  
Im Alten Dorfe 4a  
21227 Bendestorf

T: +49 (0)40 593 627 60  
[info@profinal-aluminium.de](mailto:info@profinal-aluminium.de)